

LED Pendant Series

Models: Models: VIP, SSP, SPP

LED Pendant Light

D2 Fixtures

Safety Precautions

Read all safety precautions and installation instructions carefully before installing or servicing this fixture. Failure to comply with these instructions could result in potentially fatal electric shock and/or property damage.

It is recommended that a qualified electrician perform all wiring. This fixture must be wired in accordance with all national and local electrical codes.

Do not handle any energized fixture or attempt to energize any fixture with wet hands or while standing on a wet or damp surface or in water.

Make sure the power source conforms to the requirements of the fixture. (See labels on fixture housing)

This fixture is designed for use in a 120-277 VAC, 60Hz fused circuit. The fixture is compatible with TRIAC (forward-phase or leading-edge) / ELV (reverse-phase or trailing-edge) and 0-10 V dimmers.

To reduce the risk of electrical shock, and to assure proper operation, this fixture must be adequately grounded. To accomplish proper grounding, there must be a separate ground wire (green) or bare metal contact (metal conduit) between this fixture and the ground connection of your main power supply panel. The green ground screw location is clearly marked on the fixture housing.

This fixture is intended for use for general indoor lighting in dry or damp locations only.

Assembly Instructions

1. Preparing for installation-

- Disconnect electrical power** before installing or servicing any part of this fixture.
- Remove light fixture, hardware, canopy and parts bag from carton.

2. Fixture Assembly-

- Uncoil clear cord, part of LED pendant (12) and thread the loose end through strain relief, which has 3 parts (6), (7) & (8), Thread thru small end of cone shaped part (8) first, finished side of (7) and cable grip fingers of (6) so all face down toward pendant holder, [Figure 1](#).
- Temporarily secure strain relief onto cord at desired height by tightening (8) onto plastic threaded cord grip (6) as shown in [Figure 1](#).
- Feed the clear cord through these items in the following order after the strain relief parts, (8), (7) & (6): Center hole of the canopy (5), lock washer (10) and jam nut (9) per [Figure 1 & 3](#). Thread nut (9) onto strain relief grip (6) through center hole of canopy. Tighten jam nut with lock washer onto (6), inside the canopy.
- A strip of double sided adhesive tape is provided to affix the driver to the canopy. Affix to bottom of driver, and driver to inside of canopy (5) without blocking any holes as shown in [Figure 2](#).
- Connect two pre-stripped wires from LED pendant holder (12) cord to the driver with two blue wire nuts as follows:
The (+) from (12) with a thin white stripe to the (+) red wire from driver.
The (-) from (12) to the (-) blue wire from driver.
Make any final adjustment to the length of the pendant. Excess cord fed up through the strain relief to be coiled up inside the canopy.

3. Fixture Mounting & Wiring-

All 120VAC wiring must take place inside junction box.

Caution: Make sure power is off at fuse or circuit breaker box. Check power wires for damage or scrapes. If power supply wires are within three inches of driver, use wire suitable for at least 90C (194F). **Note:** Most dwellings built before 1985 have supply wire rated to 60C. Consult a qualified electrician before installing.

- Thread two 1-1/2" long screws (2) into recessed tapped holes in gem bar (1). Secure these with nut (3) per [Figure 1](#).
- Mount gem bar (1) with (2) & (3) to junction box with two shorter screws (4).
- This unit will not operate properly unless connected to a "grounded" electrical circuit. Electrical shock, overheating, low or no light output, and shortened lamp life can result if proper grounding is not done.* Securely attach green (or green and yellow) wire from supply to green ground screw in gem bar (1).
- Bring the assembled fixture with canopy up to the junction box in the ceiling.
- Observing wire color convention, connect (hot) supply wire to black driver lead. Connect white (common) supply wire to white driver lead. Secure with orange wire nuts. Pull on each wire lead to make sure connections are secure. Make certain no bare wire is exposed outside of wire nuts.
- Make sure the connected supply wires are tucked inside of junction box.

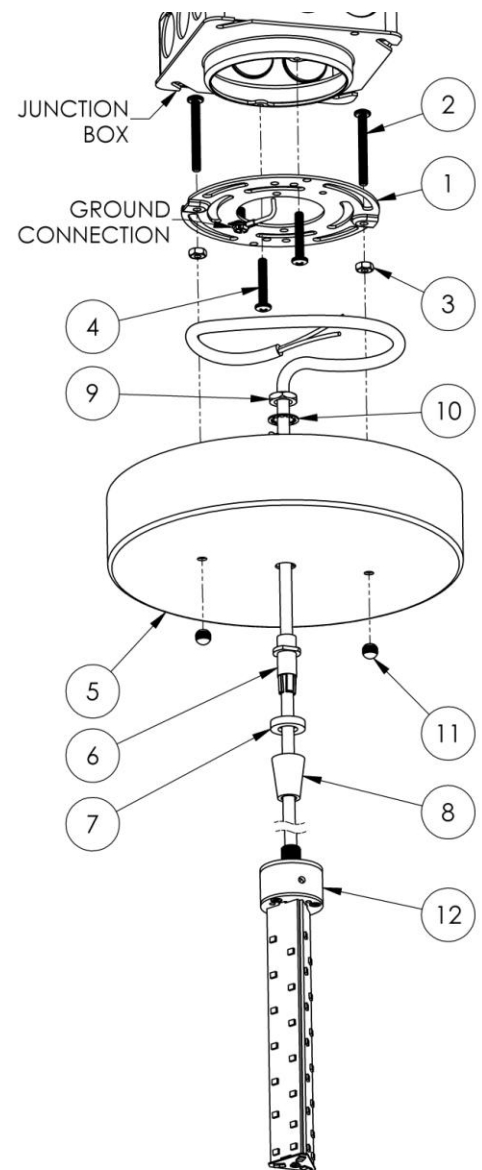

Figure 1

LED Pendant Series

Models: Models: VIP, SSP, SPP

LED Pendant Light

D2 Fixtures

- G. Place the two smaller holes in the canopy (5) onto the two screws (2) from gem bar (1). Insert any wires that may be protruding around the top of the canopy so it sits flush against the ceiling.
- H. Secure with two finial nuts (11) onto the gem bar screws.
- I. To make any final adjustment to the pendant length, loosen (8) of the strain relief. Raise pendant light to desired height pushing excess wire into the canopy, or lower pendant by bringing more wire out of the canopy.
- E. Tighten (8) completely so that the cord does not slip out through the gripper (6).

4. Glass Shade Mounting-

- A. Three threaded pins (14) hold the inner and outer glass to the pendant holder. Per [Figure 4](#), insert pins, threaded end first, into the holes in the side of outer glass (15) and then through the holes on the inner glass (13).
- B. Position the glass with pins carefully over the pendant holder (12). Thread 3 pins (14) into the tapped holes on the pendant holder so they are securely in place.
- C. Check that the pendant is hanging straight. Make any minor adjustments as needed.

5. Restore power at the fuse or breaker box.

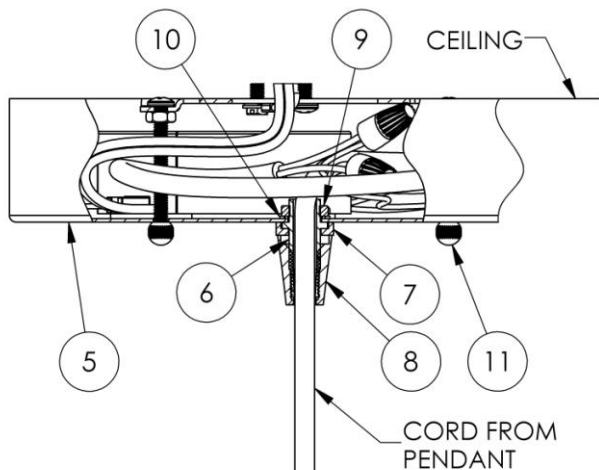

Figure 3

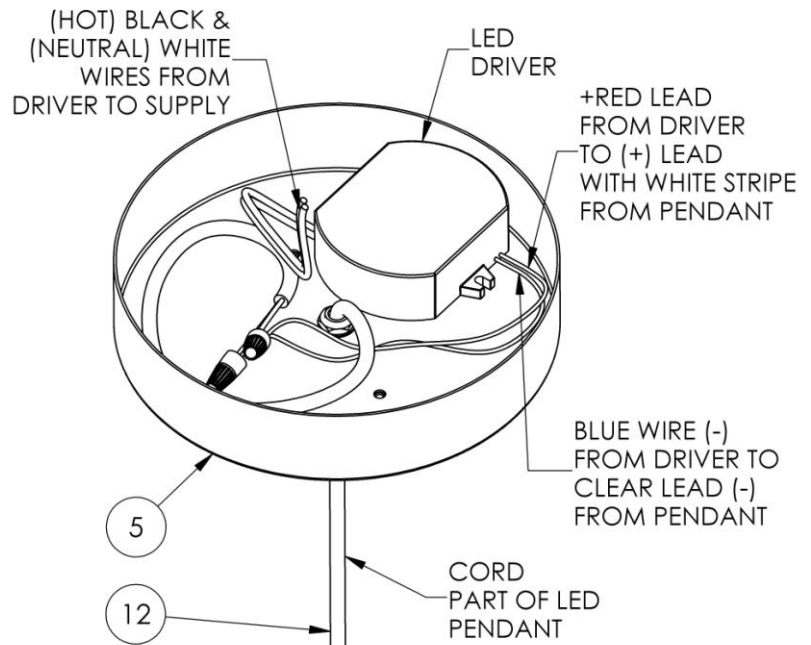
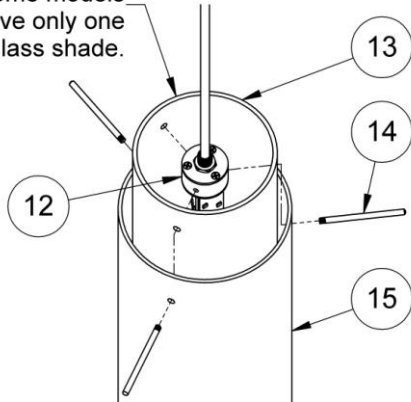

Figure 2

Note:
Some models
have only one
glass shade.



GLASS INSTALLATION

Figure 4

Limited Factory Warranty

AFX Inc. hereby warrants that this fixture is free from defects in materials and workmanship when installed and used under normal operating conditions for a period of 5 years from date of shipment from factory. This warranty covers all component parts and extends only to replacement of defective fixture or components; it does not cover failure due to improper installation, misuse, mishandling or damage incurred in transit.